INTERCONNECTION - OVERVIEW

1
2 In October 2008, RES Canada and the IESO entered into a System Impact Assessment
3 Agreement ("SIA Agreement"), pursuant to which RES Canada agreed to pay the costs
4 and expenses incurred by the IESO and by any external consultants engaged by the
5 IESO in order to complete a System Impact Assessment ("SIA") in accordance with the
6 Market Rules. A copy of the agreement is included at Exhibit F, Tab 2, Schedule 1.

7 On October 15, 2008, the IESO issued a "System Impact Assessment (Part One)
8 Report" ("Part One SIA") indicating that the proposed connection of the Greenwich
9 Windfarm to the IESO-controlled transmission grid, via the proposed Greenwich
10 Windfarm Transmission Line, was acceptable. The Part One SIA also stated that a 14
11 MVar@34.5 kV capacitor bank would be required to be installed at the 34.5 kV bus in
12 the Greenwich Windfarm Substation and that an Under Load Tap Changer may also be
13 required to be installed, depending on the results of the System Impact Assessment
14 (Part Two) Report ("Part Two SIA"). A copy of the Part One SIA is included at Exhibit F,
15 Tab 2, Schedule 2.

16 As per the IESO's SIA process, and by virtue of the selection of Greenwich Windfarm
17 through the OPA Renewable Energy Supply III ("RES III") process, the Greenwich
18 Windfarm entered the committed generation project queue, meaning that the available
19 transmission capacity of 99 MW has been reserved for this specific project.

20 On October 14, 2008, RES Canada and Hydro One entered into a Greenwich Windfarm
21 Study Proposal ("Study Proposal"), pursuant to which Hydro One agreed to prepare a
22 Customer Impact Assessment ("CIA") to assess the impact of the Greenwich Windfarm
23 on its other transmission customers in the vicinity of the project. A copy of the Study
24 Proposal is included at Exhibit F, Tab 3, Schedule 1.

25 In May 2009, a decision was made to change the model of turbine that would be used in
26 the Greenwich Windfarm. Previously, it was expected that 66 GE xle 1.5MW turbines
27 would be installed. The Applicant now plans to install 43 Siemens 2.3 MW turbines.
28 The total generation capacity or general connection requirements of Greenwich
29 Windfarm have not been materially affected by this design change. However, this
30 change necessitated the submission of an updated joint SIA/CIA application, which was
31 submitted to the IESO and to Hydro One on June 15, 2009. The updated joint SIA/CIA
32 application is currently under review by the IESO and Hydro One and is included at
33 Exhibit F, Tab 3, Schedule 2.



Greenwich Lake Wind Farm
CAA ID 2008-337

System Impact Assessment Agreement

Between

RENEWABLE ENERGY SYSTEMS CANADA INC.

as Applicant

and

INDEPENDENT ELECTRICITY SYSTEM OPERATOR

October 08, 2008

Confidential

AGREEMENT

Table of Changes

| Reference (Section and Paragraph) | Description of Change |
|---|--|
| Entire document | The deposit scheme was modified to reflect decision to assess projects individually rather than as clusters, and as such, the contingency deposit is no longer required. |
| | |
| | |
| | |
| | |
| | |

System Impact Assessment Agreement

THIS AGREEMENT dated 8th, October 2008.

BETWEEN:

Renewable Energy Systems Canada Inc. is a Corporation incorporated under the laws of Quebec, having its registered address and principal place of business at 1124 rue Marie-Anne Est, Suite 23, Montreal, Quebec H2J 2B7 Canada (the "*Connection Applicant*")

- and -

The Independent Electricity System Operator, a corporation incorporated by the *Electricity Act, 1998*, S.O. 1998, c. 15, Sched. A, having its registered address at 655 Bay Street, Suite 410, P.O. Box 1, Toronto, Ontario M5G 2K4 and its principal place of business in Ontario (the "*IESO*")

WHEREAS:

- A. The *Connection Applicant* proposes to establish a new or modify an existing *connection* to the *IESO*-controlled grid.
- B. The *Connection Applicant* has complied with the requirements set forth in section 6.1.15 of Chapter 4 of the *market rules* and has tendered to the *IESO* the *Deposit*.
- C. Section 6.1.15.3 of Chapter 4 of the *market rules* requires, as a condition of the conduct by the *IESO* of a *system impact assessment*, that the *Connection Applicant* execute this *Agreement* pursuant to which it agrees to pay:
 - (1) all of the costs and expenses incurred by the *IESO*, including the costs and expenses of the *transmitter(s)* to whose transmission *facilities* the proposed new or modified *connection* relates as invoiced to the *IESO*, in completing such *system impact assessment*, apportioned, where applicable, in accordance with sections 6.1.17 and 6.1.18 of Chapter 4 of the *market rules*, and including costs relating to *Ontario Energy Board* proceedings, and relating to any further studies performed by the *IESO* in accordance with the *Procedures*; and
 - (2) all of the costs and expenses of external consultants engaged by the *IESO* to assist in completing the *system impact assessment*.

NOW therefore, in consideration of the mutual covenants set forth herein and of other good and valuable consideration, the receipt and adequacy of which is hereby acknowledged, the *Parties* agree as follows:

ARTICLE 1
INTERPRETATION

- 1.1 **Incorporation of Market Rules Definitions:** Subject to section 1.2, italicized expressions used in this *Agreement* have the meanings ascribed thereto in Chapter 11 of the *market rules*.
- 1.2 **Supplementary Definitions:** In this *Agreement*, the following italicized expressions shall have the meanings set out below unless the context otherwise requires:
- “*Agreement*” means this *Agreement*, including the Schedules to this *Agreement*, and the expressions “hereof”, “herein”, “hereto”, “hereunder”, “hereby” and similar expressions refer to this *Agreement* and not to any particular section or other portion of this *Agreement*;
- “*System Impact Assessment Deposit*” means the deposit referred to in section 6.1.15.2 of Chapter 4 of the *market rules* and as set forth in the *Procedures*;
- “*Party*” means a party to this *Agreement* and “*Parties*” means every *Party*; and
- “*Procedures*” means the procedures referred to in section 6.1.14 of Chapter 4 of the *market rules*.
- 1.3 **Interpretation:** In this *Agreement*, unless the context otherwise requires:
- 1.3.1 words importing the singular include the plural and vice versa;
- 1.3.2 words importing a gender include any gender;
- 1.3.3 when italicized, other parts of speech and grammatical forms of a word or phrase defined in this *Agreement* have a corresponding meaning;
- 1.3.4 the expression “person” includes a natural person, any company, partnership, trust, joint venture, association, corporation or other private or public body corporate, and any government agency or body politic or collegiate;
- 1.3.5 a reference to a thing includes a part of that thing;
- 1.3.6 a reference to an article, section, provision or schedule is to an article, section, provision or schedule of this *Agreement*;
- 1.3.7 a reference to any statute, regulation, proclamation, order in council, ordinance, by-law, resolution, rule, order or directive includes all statutes, regulations, proclamations, orders in council, ordinances, by-laws or resolutions, rules, orders or directives varying, consolidating, re-enacting, extending or replacing it and a reference to a statute includes all regulations, proclamations, orders in council, rules and by-laws of a legislative nature issued under that statute;
- 1.3.8 a reference to a document or provision of a document, including this *Agreement*, the *market rules* and the *Procedures*, or a provision of this *Agreement*, the *market rules* or the *Procedures*, includes an amendment or supplement to, or replacement or novation of, that document or that provision of that document, as well as any exhibit, schedule, appendix or other annexure thereto;

- 1.3.9 a reference to a person includes that person's heirs, executors, administrators, successors and permitted assigns;
- 1.3.10 a reference to sections of this *Agreement* or of the *market rules* separated by the word "to" (i.e., "sections 1.1 to 1.4") shall be a reference to the sections inclusively;
- 1.3.11 the expression "including" means including without limitation, the expression "includes" means includes without limitation and the expression "included" means included without limitation; and
- 1.3.12 a reference in this *Agreement* to the *market rules* includes a reference to the *Procedures* and to any policies, guidelines or other documents established by the *IESO* and adopted by the *IESO Board* pursuant to section 7.7 of Chapter 1 of the *market rules*.
- 1.4 **Headings:** The division of this *Agreement* into articles and sections and the insertion of headings are for convenience of reference only and shall not affect the interpretation of this *Agreement*, nor shall they be construed as indicating that all of the provisions of this *Agreement* relating to any particular topic are to be found in any particular article, section, subsection, clause, provision, part or schedule.

ARTICLE 2 MARKET RULES

- 2.1 **Market Rules Govern:** In the event of any inconsistency between this *Agreement* and the *market rules*, the *market rules* shall prevail to the extent of the inconsistency.
- 2.2 **Compliance with Market Rules:** The *Connection Applicant* hereby agrees to be bound by and to comply with all of the provisions of the *market rules* so far as they are applicable to *connection applicants*.

ARTICLE 3 COSTS AND SCOPE OF SYSTEM IMPACT ASSESSMENT

- 3.1 **Receipt of System Impact Assessment Deposit:** The *IESO* hereby confirms payment of the *System Impact Assessment Deposit* by the *Connection Applicant*.
- 3.2 **Liability for Costs and Expenses:** The *Connection Applicant* hereby irrevocably and unconditionally agrees that it shall be liable to pay all of the costs and expenses incurred, directly or indirectly, by or on behalf of the *IESO*, including the costs and expenses of the *transmitter(s)* to whose transmission facilities the proposed new or modified facilities relates as invoiced to the *IESO*.
- 3.2.1 relating to the processing of the *Connection Applicant's request for connection assessment* since the date of the *invoice* issued to the *Connection Applicant* pursuant to section 6.1.20 of Chapter 4 of the *market rules*;
- 3.2.2 in conducting the *system impact assessment* associated with the *Connection Applicant's request for connection assessment*, apportioned if applicable in accordance with the *Procedures*;

- 3.2.3 relating to any further analysis that may be required in respect of *Ontario Energy Board* proceedings but is outside the current scope of work annexed as Schedule 1 to this *Agreement*, and to regulatory support, including legal fees, associated with the *IESO's* participation in the *Connection Applicant's* leave to construct application(s) before the *Ontario Energy Board*;
- 3.2.4 relating to any further studies, analysis and/or documentation required in respect to:
- a) the preparation of an addendum to the *system impact assessment* in accordance with the *Procedures*; or
 - b) the withdrawal of a request for connection assessment subsequent to the completion of the *system impact assessment*; and
- 3.2.5 relating to the costs and expenses incurred by external consultants engaged by the *IESO* to assist in completing the system impact assessment and any further required analysis, documentation or studies.
- 3.3 **Payment of Invoice:** The *Connection Applicant* hereby agrees that it shall, within the time stated in section 6.1.21 of Chapter 4 of the *market rules*, pay to the *IESO* any amount owing under an *invoice* submitted to it by the *IESO* pursuant to section 6.1.20 of Chapter 4 of the *market rules* and acknowledges and agrees that such amount may, without prejudice to any other manner of recovery available at law, be recovered by the *IESO* in the same manner as an obligation to make payment under the *market rules*.
- 3.4 **Refund of System Impact Assessment Deposit:** Where Article 4 does not apply, and where the aggregate amount of the costs and expenses apportioned to the *Connection Applicant* is less than the amount of the *System Impact Assessment Deposit*, the *IESO* shall refund to the *Connection Applicant* an amount equal to the amount by which the amount of the *System Impact Assessment Deposit* exceeds such aggregate amount.
- 3.5 **No Stay of Payment Obligation:** The *Connection Applicant* hereby agrees that it shall pay to the *IESO* the amount referred to in section 3.3 notwithstanding any dispute resolution process that may be initiated by the *Connection Applicant* in respect of its *request for connection assessment*, the *system impact assessment* associated with its *request for connection assessment* or this *Agreement*.
- 3.6 **Notice of Cost in Excess of Deposit:** The *IESO* shall promptly notify the *Connection Applicant* if the *IESO* expects that the costs and expenses referred to in section 3.2 are likely to exceed the amount of the *System Impact Assessment Deposit*.
- 3.7 **Scope of System Impact Assessment:** Annexed as Schedule 1 to this *Agreement* is a description of the scope of the *system impact assessment* associated with the *Connection Applicant's request for connection assessment*, as agreed to by the *IESO*, the *connection applicant* and the *transmitter(s)* to whose transmission facilities the proposed new or modified *connection* relates.

ARTICLE 4 TERMINATION

- 4.1 **Withdrawal:** The *Connection Applicant* may at any time:

- 4.1.1 withdraw its *request for connection assessment* by the giving of written notice to that effect to the *IESO* in accordance with the *Procedures*; or
- 4.1.2 be deemed to have withdrawn its *request for connection assessment* in accordance with the *Procedures*, with effect from the date of issuance to the *Connection Applicant* of a notice of deemed withdrawal by the *IESO*.
- 4.2 **Costs to Date of Withdrawal:** Upon receipt of the notice referred to in section 4.1.1 or issuance of the notice referred to in section 4.1.2, as the case may be, the *IESO* shall:
- 4.2.1 where the aggregate amount of the costs and expenses:
- (a) referred to in section 3.2.1 incurred with respect to the *Connection Applicant's request for connection assessment* on or before the date of receipt by the *IESO* of the notice referred to in section 4.1.1 or the date of issuance by the *IESO* of the notice referred to in section 4.1.2, as the case may be; and
 - (b) referred to in section 3.2.2 incurred or apportioned with respect to the *system impact assessment* associated with the *Connection Applicant's request for connection assessment* on or before the date of receipt by the *IESO* of the notice referred to in section 4.1.1 or the date of issuance by the *IESO* of the notice referred to in section 4.1.2, as the case may be,
- exceeds the amount of the *System Impact Assessment Deposit*, submit to the *Connection Applicant* an *invoice* for the amount by which the aggregate amount of such costs and expenses exceeds the amount of the *System Impact Assessment Deposit*; or
- 4.2.2 subject to section 4.3, and in accordance with the *Procedures*, where the costs and expenses referred to in section 4.2.1 are less than the amount of the *System Impact Assessment Deposit*, refund to the *Connection Applicant* an amount equal to the amount by which the amount of the *System Impact Assessment Deposit* exceeds such costs and expenses.
- 4.3 **Costs after the Date of Withdrawal:** Where costs and expenses are incurred by the *IESO* or the *transmitter(s)*, to whose transmission *facilities* the proposed new or modified connection relates, to repeat connection assessment studies or to conduct additional studies as a result of the *Connection Applicant* withdrawing its *request for connection assessment*, the *Connection Applicant* agrees to pay the costs and expenses associated with such repeated or additional studies up to a maximum amount of \$15,000.
- 4.4 **Liability for Costs:** The *Connection Applicant* hereby irrevocably and unconditionally agrees that, in the event that it withdraws or is deemed to have withdrawn its *request for connection assessment*, it shall pay to the *IESO* the amount specified in any *invoice* received by it pursuant to section 4.2.1 and, where applicable, section 4.3, within ten *business days* of receipt of such *invoice*. The *Connection Applicant* acknowledges and agrees that such *invoice* shall be considered to create an obligation under the *market rules* to pay the amount specified in such *invoice* and that such amount may, without prejudice to any other manner of recovery available at law, be recovered by the *IESO* accordingly.
- 4.5 **Payment of Invoice:** The *Connection Applicant* hereby agrees that it shall pay to the *IESO* the amount referred to in section 4.4 notwithstanding any dispute resolution process that may be

initiated by the *Connection Applicant* in respect of its *request for connection assessment*, the *system impact assessment* associated with its *request for connection assessment* or this *Agreement*.

4.6 **No Obligation to Remit Reports Etc.:** Where the *Connection Applicant's request for connection assessment* has been withdrawn or has been deemed to have been withdrawn, the *IESO* shall have no obligation to provide the *Connection Applicant* with any information or documentation pertaining to or comprising, in whole or in part, the *system impact assessment* associated with its *request for connection assessment*, including any report or study relating thereto.

4.7 **Termination and Survival:** This *Agreement* shall terminate on:

4.7.1 the date of receipt by the *IESO* of the notice referred to in section 4.1.1 or the date of issuance by the *IESO* of the notice referred to in section 4.1.2, as the case may be; or

4.7.2 the date on which the *IESO* tenders to the *Connection Applicant* the report of the results of the completed *system impact assessment* associated with the *Connection Applicant's request for connection assessment*,

whichever is the earlier, provided that sections 3.2, 3.3, 3.4, 4.2, 4.3, 4.4, 4.5 and 4.6, as may be applicable, shall survive the termination of this *Agreement* until such time as payment has been made as required thereby.

ARTICLE 5

FURTHER INFORMATION AND DOCUMENTATION

5.1 **Obligation to Provide Information:** The *Connection Applicant* hereby agrees to provide the *IESO* with such information and documentation as the *IESO* may reasonably request for purposes of the completion of the *system impact assessment* associated with the *Connection Applicant's request for connection assessment*. Such information shall be provided within the time noted in the request or within such longer period of time as may be agreed between the *IESO* and the *Connection Applicant*.

5.2 **Failure to Provide Information:** The *Connection Applicant* hereby acknowledges and agrees that, in accordance with the *Procedures*, the failure by it to provide the information requested pursuant to section 5.1 within the time noted in the request constitutes a grounds upon which its *request for connection assessment* may be deemed to have been withdrawn.

5.3 **Disclosure of Information to Transmitter(s):** The *Connection Applicant* hereby agrees that the *IESO* may disclose such information and documentation as may be reasonably requested by the *transmitter(s)* to whose facilities the proposed new or modified connection relates, in order for the *transmitter(s)* to discharge its responsibilities in respect to the *system impact assessment* of the proposed new or modified connection, as set out in the *Procedures*.

5.4 **Disclosure of Information to External Consultants:** The *Connection Applicant* hereby agrees that the *IESO* may disclose relevant information, including without limitation *confidential information*, and documentation to external consultants retained by the *IESO* to assist in completing the *System Impact Assessment*. Such information is information that may be reasonably required by the consultants to perform, or assist in performing the *System Impact Assessment*.

- 5.5 **Publication of System Impact Assessment Report:** The *Connection Applicant* hereby agrees that the *IESO* may publish the *System Impact Assessment Report* pertaining to the proposed new or modified connection, in accordance with the *Procedures*.

ARTICLE 6

REPRESENTATIONS AND WARRANTIES

- 6.1 **Representations and Warranties of the IESO:** The *IESO* hereby represents and warrants as follows to the *Connection Applicant*, and acknowledges and confirms that the *Connection Applicant* is relying on such representations and warranties:
- 6.1.1 that the execution, delivery and performance of this *Agreement* by it has been duly authorized by all necessary corporate and/or governmental action; and
- 6.1.2 that this *Agreement* constitutes a legal and binding obligation on the *IESO*, enforceable against the *IESO* in accordance with its terms.
- 6.2 **Representations and Warranties of the Connection Applicant:** The *Connection Applicant* hereby represents and warrants as follows to the *IESO*, and acknowledges and confirms that the *IESO* is relying on such representations and warranties:
- 6.2.1 that the execution, delivery and performance of this *Agreement* by it has been duly authorized by all necessary corporate and/or governmental action; and
- 6.2.2 that this *Agreement* constitutes a legal and binding obligation on the *Connection Applicant*, enforceable against the *Connection Applicant* in accordance with its terms.

ARTICLE 7

MISCELLANEOUS

- 7.1 **Amendment:** No amendment of this *Agreement* shall be effective unless made in writing and signed by the *Parties*.
- 7.2 **Assignment:** The *Connection Applicant* may not assign or transfer, whether absolutely, by way of security or otherwise, all or any part of its rights or obligations under this *Agreement* without the prior written consent of the *IESO*. The *IESO* may not assign or transfer, whether absolutely, by way of security or otherwise, all or any part of its rights or obligations under this *Agreement* without the prior written consent of the *Connection Applicant*.
- 7.3 **Successors and Assigns:** This *Agreement* shall enure to the benefit of, and be binding on, the *Parties* and their respective heirs, administrators, executors, successors and permitted assigns.
- 7.4 **Further Assurances:** Each *Party* shall promptly execute and deliver or cause to be executed and delivered all further documents in connection with this *Agreement* that the other *Party* may reasonably require for the purposes of giving effect to this *Agreement*.
- 7.5 **Waiver:** A waiver of any default, breach or non-compliance under this *Agreement* is not effective unless in writing and signed by the *Party* to be bound by the waiver. No waiver will be inferred or implied by any failure to act or by the delay in acting by a *Party* in respect of any default, breach or non-observance or by anything done or omitted to be done by the other *Party*. The

waiver by a *Party* of any default, breach or non-compliance under this *Agreement* shall not operate as a waiver of that *Party's* rights under this *Agreement* in respect of any continuing or subsequent default, breach or non-observance (whether of the same or any other nature).

- 7.6 **Severability:** Any provision of this *Agreement* that is invalid or unenforceable in any jurisdiction shall, as to that jurisdiction, be ineffective to the extent of that invalidity or unenforceability and shall be deemed severed from the remainder of this *Agreement*, all without affecting the validity or enforceability of the remaining provisions of this *Agreement* or affecting the validity or enforceability of such provision in any other jurisdiction.
- 7.7 **Notices:** Any notice, demand, consent, request or other communication required or permitted to be given or made under this *Agreement* shall:
- 7.7.1 be given or made in the manner set forth in section 8.1 of Chapter 1 of the *market rules*;
- 7.7.2 be addressed to the other *Party* in accordance with the information set forth in Schedule 2; and
- 7.7.3 be treated as having been duly given or made in accordance with the provisions of section 8.2 of Chapter 1 of the *market rules*.
- Either *Party* may change its address and representative as set forth in Schedule 2 by written notice to the other *Party* given as aforesaid. Such change shall not constitute an amendment to this *Agreement* for the purposes of the application of section 7.1.
- 7.8 **Governing Law:** This *Agreement* shall be governed by and construed in accordance with the laws of the Province of Ontario and the federal laws of Canada applicable therein.
- 7.9 **Attornment:** Subject to section 7.10, the *Connection Applicant* hereby irrevocably and unconditionally submits, for itself and its property, to the exclusive jurisdiction of the courts of Ontario in any action or proceeding arising out of or relating to this *Agreement* or for the recognition and enforcement of any judgment. Each of the *Parties* hereby agrees that a final judgment in any such action or proceeding shall be conclusive and may be enforced in other jurisdictions in any manner permitted by law. Nothing in this *Agreement* shall preclude the *IESO* from bringing any action or other proceeding relating to this *Agreement* against the *Connection Applicant* or its properties in any other jurisdiction.
- 7.10 **Dispute Resolution:** Except as may otherwise be provided in the *market rules*, any disputes arising under this *Agreement* shall be resolved using the dispute resolution process set out in section 2 of Chapter 3 of the *market rules*.
- 7.11 **Counterparts:** This *Agreement* may be executed in any number of counterparts, each of which shall be deemed to be an original and all of which taken together shall be deemed to constitute one and the same instrument. Counterparts may be executed either in original or faxed form and the *Parties* adopt any signatures received by a receiving facsimile machine as original signatures of the *Parties*; provided, however, that any *Party* providing its signature in such manner shall promptly forward to the other *Party* an original signed copy of this *Agreement* which was so faxed
- 7.12 **Liability:** The provisions of section 13 of Chapter 1 of the *market rules* apply to this *Agreement* and are hereby incorporated by reference herein, with all references in such section to a *market participant* being deemed to be references to the *Connection Applicant*.

IN WITNESS WHEREOF the Parties have, by their duly appointed and authorized representatives, executed this Agreement.

Renewable Energy Systems Canada Inc.

By: 

Name: ~~Nicolas Muszynski~~ Peter Clibbon
Title: ~~Development Manager~~ Vice-President

Date: 25 September, 2008

INDEPENDENT ELECTRICITY SYSTEM OPERATOR

By: 

Name: Kim Warren
Title: Director - Planning & Assessments

Date: Oct 08/08

SCHEDULE 1
SCOPE OF WORK
Greenwich Lake Wind Farm: CAA ID 2008-337

1. General

Renewable Energy Systems Canada Inc. is proposing to develop a 99 MW wind farm located about 60 km northeast of Thunder Bay, Ontario. The development will consist of a total of 66 GE 1.5 XLE 1.5 MW 60 Hz wind turbine generators. The power from the wind farm will be injected into Ontario power grid via two three phase 34.5/230 kV transformers plus approximately 11 km 230 kV overhead line, tapped on Hydro One's 230 kV circuit M23L and M24L. The tap point is about 47 km east of Lakehead TS.

The scheduled permanent in-service date is Q3 2010.

2. Assessment Assumptions

- The assessment will be performed based on related procedures and guideline documents that are in force at the time of the assessment.
- The system model will include transmission projects committed and under construction, all existing generators (including upgrading capacity at existing generating facilities), and new generators that were selected in all procurement processes completed to date, have signed a contract with a purchaser, or have signed a connection cost recovery agreement with a transmitter.

3. Assessment Process

The assessment for this Project is to be performed in two discrete stages:

LINE Part 1: Part 1 will primarily look at the feasibility of the proposed connection arrangement of the Project and the impact of the new generating facility on the local transmission facilities. Computer simulations will be strictly limited to a cursory check of acceptability of steady state under normal operating conditions. If the Project has material impact on the local transmission, (i) the connection arrangement should be revised, or (ii) the local transmission should be proposed to be upgraded, or (iii) maximum generating capability for the Project should be determined. Part 1 will also examine data, models and dynamic performance of the new facilities to check the facility's compliance to the Market Rules.

Part 2: Part 2 will perform a thorough investigation on the Project's impact on the IESO-controlled grid. Computation simulations will include power flow, short circuit, transient stability analyses under normal conditions, contingencies, and faults. The impact on the existing interfaces in the IESO-controlled grid will be evaluated. To minimize the adverse impact on the transmission system, some actions will be proposed including installing new transmission facilities, installing static and dynamic reactive power facilities, parameters adjustment/optimization of the control system, upgrading circuit breakers, developing special protection schemes.

Part 1 of the SIA is applicable to those *connection applicants* who are planning to participate in a procurement process, such as a Request For Proposal (RFP) initiated by the OPA, where connection costs must be covered by the offer price. This assessment would provide the *connection applicant* with information regarding connection requirements that are necessary to formulate an offer price.

Part 2 of the SIA will only be completed if the Project is selected and awarded a contract in the procurement process or an RFP, unless the *connection applicant* clearly requests that Part 2 be completed regardless of the results of the procurement process or RFP.

3.1 Part 1 Assessment

The work that is to be performed under Part 1 of the assessment will be as follows:

3.1.1 Connection Arrangement

Review and comment on the proposed connection arrangement for the Project. Check the data and models of the new facilities, the facility's compliance to the Market Rules and Transmission Code by inspection of data, and the intended mode of operation.

3.1.2 Power System Analysis

- Perform a limited number of load flow studies to determine the impact of the Project on the local transmission facilities under steady-state normal operating conditions, if necessary.
- Confirm that the ratings of the local transmission facilities, with consideration to various modes of operation, will be adequate to accommodate the Project.
- If the Project has a material impact on the local transmission system, evaluate the maximum amount of generating capacity that could be incorporated without major transmission reinforcements.
- Identify the local system upgrade that may be required to allow the full output of the Project.
- Identify the need for generation rejection or generation run-back to avoid overloading the remaining transmission facilities following a system contingency.

3.1.3 Data Verification

- Review the data provided for the equipment to be installed. Advise the *connection applicant* of any omissions, errors or data that appears inadequate.
- Evaluate dynamic performance of individual facilities, if applicable.

3.1.4 Report

If required, issue a report summarizing the results of Part 1, together with any specific requirements for the proposed connection to the IESO-controlled grid.

3.2 Part 2 Assessment

The system model to be used in Part 2 assessment will include, in addition to the assumptions listed in Section 2 above, all other generation projects that were selected in the procurement process in which the Project was also successful.

The work that is to be performed under Part 2 of the assessment will be as follows:

3.2.1 Short Circuit Assessment (by Transmitter)

Perform fault level analysis.

- Identify any breakers whose fault interrupting capability would be inadequate for the projected fault levels arising from the incorporation of the Project.
- Examine measures that could be implemented to avoid the need for replacing breakers and confirm that they would be effective (i.e. installing reactors; introducing normally-open points; operating with busbars split; etc.)

3.2.2 Steady State Analysis

Perform other Load Flow Studies that may be required in addition to those performed in Part 1.

- Determine the impact of the Project on the thermal ratings of the existing transmission facilities.

- Identify the system upgrades that may be required to allow the full output of the Project to be accommodated with all existing transmission elements in-service.
- Identify additional requirements for generation rejection or generation run-back (other than those identified in Part 1 of the Assessment), to avoid overloading the remaining transmission facilities following a system contingency. Produce the functional description for a suitable SPS and perform necessary analysis to support determination of NPCC Type status.
- Identify the effect of the Project on the transfer capability of selected transmission interfaces or on existing system operating limits.
- Identify the need for system upgrades that may be required to restore the transfer capabilities of the interfaces or the system operating limits to their former levels.

Perform Voltage Decline Studies.

- Perform load flow voltage analysis to determine the effect of the Project on the existing local transmission system, and affected transmission interfaces.
- Examine the effect of the loss of the Project on local voltages. If the voltage declines are in excess of the voltage change limits specified in the IESO Transmission Assessment Criteria document, the IESO will investigate possible options for limiting them.
- If the Project has a material impact on the transmission system, evaluate the maximum amount of generating capacity that could be incorporated without major transmission reinforcements.
- Determine the effect of transmission contingencies resulting in the loss of the Project on local voltages.

3.2.3 Transient State Analysis

- Examine the dynamic performance of the new generating units under fault conditions. Identify any deficiencies with the facilities.
- Verify the adequacy of low voltage ride through capability for the wind-turbine technology proposed for the Project.
- Determine the reactive power compensation required to be installed at the generating facility to provide adequate dynamic voltage control and compensate for the wind farm collector system excessive reactive losses, if necessary.

3.2.4 Report

Issue a report summarizing the combined results of Parts 1 & 2 of the IESO's Assessment for the Project.

4. Reporting & Schedule

The connection assessment process for the Project will be completed by the IESO on a best effort basis, as determined by number of other connection assessments underway, and as negotiated with the *connection applicant* with due consideration to the project completion schedule.

If this proposal is to be registered in an upcoming capacity or energy procurement process, the IESO will complete Part 1 SIA or the work necessary to meet the mandatory technical requirements expressed in the terms and conditions of the procurement process for which the proposal is to be registered, whichever is less, in advance of the proposal submission deadline.

If a consultant is retained by the connection applicant to perform Part 1 SIA, following execution of SIA and ND agreements, IESO staff is prepared to meet with the consultant to discuss the scope of Part 1 connection assessment, as well as reporting requirements. The *connection applicant* will be charged for IESO time and expenses associated with this meeting. Part 1 assessment must be completed and a report

issued by the consultant to the IESO for review 30 days prior to the proposal submission deadline, where applicable.

Part 2 SIA will be performed by the IESO only after the proposal is selected in a procurement process.

Upon completion of Part 2 study, a preliminary version of the draft SIA report will be circulated to the *connection applicant*, and the Transmitter for comments.

Once agreement has been reached on the contents of the draft version of the SIA Report, a copy will be posted on the IESO web site. This is expected to occur at a date which is mutually acceptable to the IESO and to the *connection applicant*.

Once the draft version of the SIA Report has been posted on the IESO web site, the Transmitter will be in a position to proceed with the Customer Impact Assessment (CIA). The *connection applicants* are required to initiate the CIA process with the Transmitter well in advance of the completion of the. A period of 30 calendar days is required for the receipt of preliminary responses to the CIA from any affected customers in the area. Any additional comments from the *connection applicant* or from the Transmitter on the draft SIA Report are also expected to be received during this period. The SIA Report will be finalized based on these comments.

The Transmitter's Customer Impact Assessment process allows a period of 90 calendar days from the date that the draft SIA Report is posted on the IESO web site for the CIA Report to be issued. This is to permit detailed studies to be performed to quantify the specific impact of the new Project on adjacent customers' facilities. Should the subsequent comments from affected customers merit significant changes to the final version of the SIA Report, then these would be need to be addressed in an Addendum to the SIA Report.

5. Record of Time & Expenses

For the IESO's activities, all time and expenses spent on this assessment are to be recorded, and an invoice issued as soon as possible following the completion of the assessment. If the total costs of the assessment are less than the deposit, the *connection applicant* will receive a refund.

SCHEDULE 2

NOMINATED REPRESENTATIVES FOR OFFICIAL NOTIFICATIONS

[Section 7.7]

IESO

| | |
|------------------------------|--|
| Name of IESO Representative: | MICHAEL FALVO |
| Title: | MANAGER, TRANSMISSION ASSESSMENTS & PERFORMANCE |
| Address: | STATION A BOX 4474 |
| City/Province/Postal Code: | TORONTO, ONTARIO M5W 4E5 |
| Email address: | mike.falvo@ieso.ca |
| Phone: | (905) 855-6209 |
| Fax: | (905) 855-6372 |

Renewable Energy Systems Canada Inc.

| | |
|---|--|
| Name of <i>Connection Applicant</i> Representative: | NICOLAS MUSZYNSKI |
| Title: | Development Manager |
| Address: | 1124 rue Marie-Anne Est, Suite 23 |
| City/Province/Postal Code: | Montreal, Quebec H2J 2B7 Canada |
| Email address: | nicolas.muszynski@res-americas.com |
| Phone: | 514-525-2113 |
| Fax: | 514-525-2113 |

CONNECTION ASSESSMENT & APPROVAL PROCESS

System Impact Assessment (Part One) Report

Greenwich Lake Wind Farm

Applicant: **Renewable Energy Systems Canada Inc.**

CAA ID 2008-337

Transmission Assessment and Performance Department

Independent Electricity System Operator
Ontario

October 15, 2008

System Impact Assessment (Part One) Report

Greenwich Lake Wind Farm

Disclaimers

IESO

This report has been prepared solely for the purpose of assessing whether the connection applicant's proposed connection with the IESO-controlled grid would have an adverse impact on the reliability of the integrated power system and whether the IESO should issue a notice of approval or disapproval of the proposed connection under Chapter 4, section 6 of the Market Rules.

Approval of the proposed connection is based on information provided to the IESO by the connection applicant and the transmitter(s) at the time the assessment was carried out. The IESO assumes no responsibility for the accuracy or completeness of such information, including the results of studies carried out by the transmitter(s) at the request of the IESO. Furthermore, the connection approval is subject to further consideration due to changes to this information, or to additional information that may become available after the approval has been granted. Approval of the proposed connection means that there are no significant reliability issues or concerns that would prevent connection of the proposed facility to the IESO-controlled grid. However, connection approval does not ensure that a project will meet all connection requirements. In addition, further issues or concerns may be identified by the transmitter(s) during the detailed design phase that may require changes to equipment characteristics and/or configuration to ensure compliance with physical or equipment limitations, or with the Transmission System Code, before connection can be made.

This report has not been prepared for any other purpose and should not be used or relied upon by any person for another purpose. This report has been prepared solely for use by the connection applicant and the IESO in accordance with Chapter 4, section 6 of the Market Rules. The IESO assumes no responsibility to any third party for any use, which it makes of this report. Any liability which the IESO may have to the connection applicant in respect of this report is governed by Chapter 1, section 13 of the Market Rules. In the event that the IESO provides a draft of this report to the connection applicant, you must be aware that the IESO may revise drafts of this report at any time in its sole discretion without notice to you. Although the IESO will use its best efforts to advise you of any such changes, it is the responsibility of the connection applicant to ensure that it is using the most recent version of this report.

This assessment identifies the impact of the new generating proposal on the local transmission facilities surrounding the proposed connection point. This assessment does not look at the impact of the project on the overall system reliability such as impact on system fault levels, transmission interface capability and system operating limits. This assessment does not identify the effect of this project on transmission congestion nor does it take into consideration the capacity limitations of the particular zone, if applicable.

Table of Contents

| | |
|---|----|
| TABLE OF CONTENTS..... | I |
| LIST OF FIGURES | II |
| 1. PROJECT DESCRIPTION | 1 |
| 2. SCOPE OF PART ONE ASSESSMENT..... | 3 |
| 3. GENERAL REQUIREMENTS..... | 5 |
| 4. GENERAL ASSESSMENT | 9 |
| 4.1 Connection Arrangement | 9 |
| 4.2 Connection Equipment..... | 9 |
| 5. LOAD FLOW ASSESSMENT | 10 |
| 5.1 Models and Data | 10 |
| 5.2 Current Conditions | 11 |
| 5.3 Voltage Control..... | 13 |
| 5.3.1 Dynamic Reactive Power Capability | 13 |
| 5.3.2 Static Reactive Compensation | 13 |
| 5.3.3 Steady State Loading | 14 |
| 6. CONCLUSIONS AND REQUIREMENTS..... | 16 |

List of Figures

| | |
|---|----|
| Figure 1: Connection Arrangement..... | 2 |
| Figure 2: Standards for Setting Under-frequency Trip Protection for Generators..... | 7 |
| Figure 3: MW flow on M23L at Lakehead TS..... | 11 |
| Figure 4: MW flow on M23L at Marathon TS | 12 |
| Figure 5: Voltage at Lakehead TS | 12 |
| Figure 6: Voltage at Marathon TS..... | 13 |

Greenwich Lake Wind Farm

1. Project Description

The *Renewable Energy Systems Canada Inc.* (RES) has proposed to develop a 99 MW wind farm located in the west of Dorion, Ontario, known as Greenwich Lake Wind Farm. The project will participate in Ontario government's RFP III, and if a contract is awarded it is expected that commercial operation will start at the forth quarter of 2012.

The Greenwich Lake Wind Farm will be connected to Hydro One's 230-kV circuits M23L and M24L via a new 230-kV 2×40/50/60-MVA interconnection substation located about 11 km far from the Hydro One right-of-way. The substation is connected to the 230-kV circuits by means of a selector switching system in which two 230-kV circuits are tapped separately. The new substation will consist of two 34.5/230 kV transformers, two 230-kV circuit breakers and associated switchgears, two 34.5-kV buses, and 4 collector line breakers. Each 34.5-kV bus is connected to the step-up transformer via a disconnect switch.

The wind farm will consist of 66 GE XLE 1.5 MW Wind Turbine Generators (WTGs). The WTG units will be arranged in four groups of 17 or 16 units each. Each group will be collected onto one collector line which will be connected to the 34.5-kV bus at the new substation via a circuit breaker.

Figure 1 shows the single line diagram of the proposed connection of Greenwich Lake Wind Farm.

| Circuit ID | C1 | C2 | C3 | C4 | Total |
|----------------------|----|------|----|------|-------|
| Number of generators | 17 | 16 | 17 | 16 | 66 |
| Maximum MW | 24 | 22.5 | 24 | 22.5 | 99 |

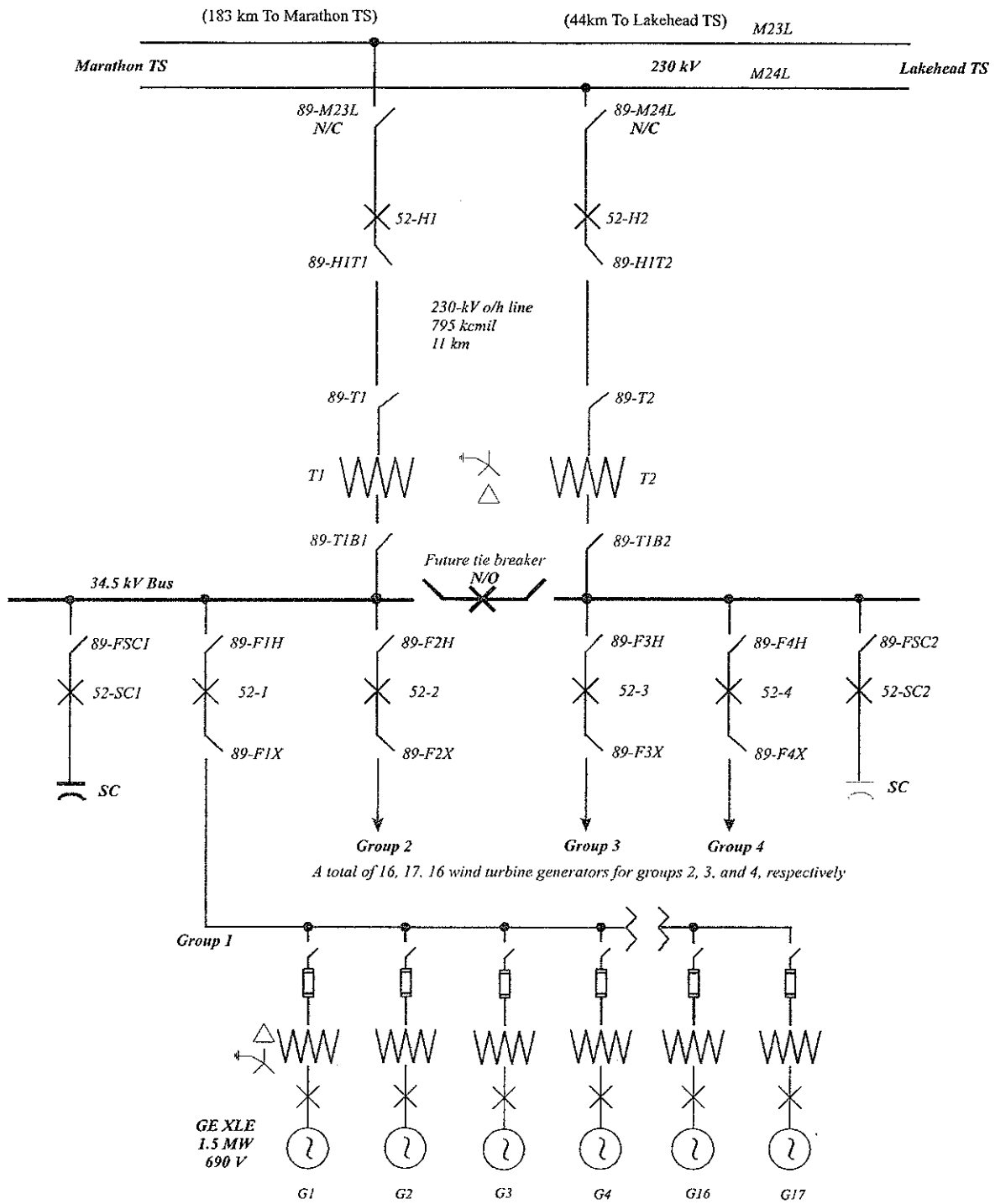

Figure 1: Connection Arrangement

- End of Section -

2. Scope of Part One Assessment

The scope of the Part One System Impact Assessment (SIA) is limited to a review of the project details and an assessment of impact on the local facilities of the IESO-controlled grid surrounding the proposed connection point. This includes:

- Check the completeness of data and models.
- Check the compliance of data and models to IESO Market Rules and the Ontario Transmission System Code.
- Check the suitability of the proposed connection arrangement and mode of operation.
- Check the thermal loading impact of the proposed facility on the local transmission facilities.
- Review the reactive power capability associated with the wind turbine technology.
- Identify the need for any specific equipment requirements and the approximate level of any reactive power compensation required.

The system model includes local transmission projects committed and under construction, existing generators including upgrading capacity at existing facilities, new generators that were selected in all procurement processes completed to date, projects that have signed a contract with a purchaser or have signed a connection cost recovery agreement with a transmitter by the in-service date of the proposed project. The computer simulations performed will strictly be limited to cursory check of acceptability of the steady state under all elements in-service, unstressed and normal operating conditions.

The Part One SIA does NOT cover the following analyses, which belong to the scope of the Part Two SIA:

- Perform fault level analysis to identify any breakers whose fault interrupting capability would be inadequate for the projected fault levels arising from the incorporation of the facility.
- Identify the effect of the facility on the transfer capability of selected transmission interfaces and on existing system operating limits.
- Identify the need for system upgrades that may be required to restore the transfer capabilities of the interfaces or the system operating limits to their former levels.
- Identify additional requirements for generation rejection or generation run-back to avoid overloading the remaining transmission facilities following a system contingency.
- Produce the functional description for a suitable SPS and perform necessary analysis to support determination of NPCC Type status.
- Examine the dynamic performance of the facility under fault conditions.
- Verify the adequacy of voltage ride through capability for the employed wind turbine technology.

The Part Two SIA will ensure that integration of the proposed facility does not compromise the overall reliability of the IESO-controlled grid and that adequate transmission is available. Some of the analyses will be done in conjunction with the transmitter.

This assessment does not identify the effect of this project on transmission congestion nor does it take into consideration the capacity limitations of the particular zone, if applicable.

– End of Section –

3. General Requirements

The general requirements for connection of the new facility include, but not limited to the following items. The complete list of requirements and their specifics will be identified during Part Two SIA.

Generators

The proposed facility must satisfy the generator facility requirements in Appendix 4.2, References 1 to 11, Reference 13 and the voltage response time requirement in Reference 12 of the Market Rules.

In particular, references 1.4 and 2 require that a generating facility connecting to the IESO-controlled grid must have the minimum capability to perform the following:

- Supply reactive power continuously in the range of 0.9 lagging to 0.95 leading power factor based on active power output at its generator terminals for at least one constant 230 kV system voltage, and
- supply full active power continuously while operating at a generator terminal voltage ranging from 0.95 pu to 1.05 pu of the generator's rated terminal voltage.

For a single generator connected to a generator step-up transformer which is in turn connected to the IESO-controlled grid, the above two requirements effectively limit the impedance between the generator terminals and the HV side of the transformer to a maximum of 0.13 pu based on the MVA rating of the generation facility, which is normally based on the maximum continuous active power rating at a 0.9 power factor. However, if a generator is capable of supplying the full reactive power range at its terminals for at least one constant system voltage while operating at a terminal voltage outside the range between 0.95 pu and 1.05 pu, the effective maximum impedance allowed between the generator terminals and the HV side of the generator step-up transformer could be higher than 0.13 pu.

Assuming the facility has a capability to operate from 0.95 pu to 1.05 pu of the generator's rated terminal voltage, the following reactive power requirements, as measured at the connection point, must be supplied:

- The reactive power required to be injected by the facility at the point of connection is +0.35 pu of active power (based on a maximum effective facility impedance of 0.13 pu), and the reactive power required to be absorbed by the facility at the point of connection is -0.33 pu of rated active power.
- A facility deficient in the above reactive power requirements must install additional reactive compensation devices. Specifically, the IESO has identified the following requirements for compensation devices:

For WTGs that have dynamic reactive power capabilities described in Appendix 4.2, Reference 1 of the Market Rules, shunt capacitors may be required to offset the reactive power losses within the facility in excess of the maximum allowable losses.

For WTGs that do not have dynamic reactive power capabilities described in Appendix 4.2, Reference 1 of the Market Rules, dynamic reactive compensation devices must be installed to make up the deficient reactive power capabilities as required in Appendix 4.2, Reference 1. In addition, shunt capacitors may be required to offset the reactive power losses within the facility in excess of the maximum allowable losses.

The WTGs must be able to ride through recognized contingencies in the IESO-controlled grid that do not disconnect the facility by configuration. This will require adequate low and high voltage ride-through capability.

The connection and disconnection of the WTGs must minimize any adverse effects on the IESO-controlled grid.

Connection Equipment (Breakers, Disconnects, Transformers, Buses)

High voltage 230 kV equipment connected to terminal stations must be capable of continuously operating in the range between 220 kV and 250 kV (Appendix 4.1, Reference 2 of the Market Rules).

Some recognized contingencies (e.g. load shedding, open line end) can cause a temporary voltage increase above the maximum continuous limit of 250 kV. For these conditions, connection equipment may be exposed to voltages slightly above its maximum continuous rating for the short period of time that it takes the IESO to direct operations to restore a normal voltage profile, and to prepare for the next contingency. This re-preparation period will be as short as possible, but it will not take longer than 30 minutes.

Therefore, the IESO requires that the 230 kV connection equipment have the following requirements: connection equipment must have a maximum continuous voltage rating of at least 250 kV in southern Ontario, equipment must be able to interrupt rated fault current for voltages up to the maximum continuous rating, and equipment must remain in service, and not automatically trip, for voltages up to 5% above the maximum continuous rating, for up to 30 minutes, to allow the system to be re-dispatched to return voltages within their normal range.

The Transmission System Code (TSC), Appendix 2 states that 230 kV connection equipment should have a rated 3-phase symmetrical short circuit capability of 63 kA and a rated single line to ground (SLG) symmetrical short circuit capability of 80 kA (usually limited to 63 kA). The TSC also requires that 230 kV breakers have a rated interrupting time of three cycles (50 ms) or less.

Connection equipment must be designed so that the adverse effects of failure on the IESO-controlled grid are mitigated. This includes ensuring that all breakers fail in the open position. Connection equipment must be designed so that it will be fully operational in all reasonably foreseeable ambient temperature conditions. This includes ensuring that SF6 breakers are equipped with heaters to prevent freezing.

Protection Systems

Faults within the facility must not trip the 230 kV circuits M23L and/or M24L except for the failure of the Greenwich Lake 230 kV connection breaker 52-H1 and/or 52-H2. After the facility begins commercial operation, if the tripping of M23L and/or M24L occurs due to events within Greenwich Lake Wind Farm, the facility may be required to be disconnected until the problem is solved.

Protection systems must be designed to meet all the requirements of the Transmission System Code as specified in Schedules E, F and G of Appendix 1 (Version B) and any additional requirements identified by Hydro One. Where required by Hydro One, protection systems at Greenwich Lake

Wind Farm must be coordinated with Hydro One protections systems.

The generators are required to be able to operate continuously at full power for frequencies between 59.4 to 60.6 Hz. The facility must be capable of operating at full active power for a limited period of time for frequencies as low as 58.8 Hz. The wind turbine generators (WTGs) must not trip for under-frequency system conditions that are below 60 Hz but above 57.0 Hz and above the curve shown in Figure 2.

Figure 2: Standards for Setting Under-frequency Trip Protection for Generators

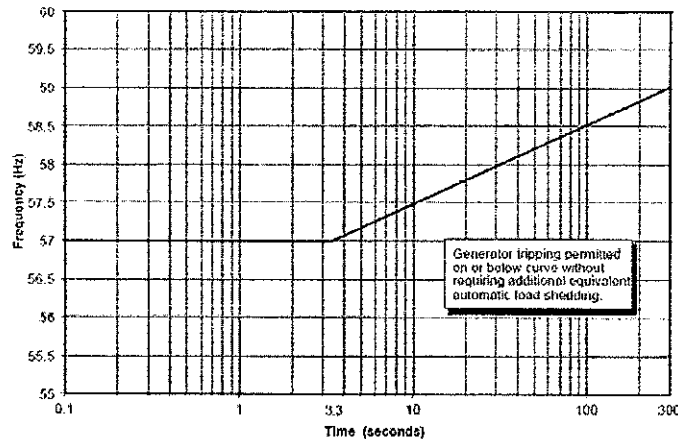

IESO Monitoring and Telemetry Data

The Market Rules (Appendix 4.15 and Appendix 4.19) list the requirements with respect to the telemetry data that must be provided to the IESO and to the performance standards that must be achieved on a continual basis by all generators.

In accordance with the telemetry requirements for a *major generation facility*, equipment must be installed at the proposed facility with specific performance standards that provides telemetry data to the IESO. The data is to consist of certain equipment status and operating quantities which will be identified during the IESO Market Entry Process.

Miscellaneous

The facility must be operated in voltage control mode at the xx.x kV bus by employing a voltage management system that controls the bus voltage to a set point to be determined by the IESO. The voltage management system must provide the coordinated operation of all sources of reactive power to avoid 'hunting' among the various sources. Operation of the facility in power factor control or reactive power control is not acceptable unless required by the IESO.

The station service equipment and plant auxiliaries shall be capable of operating continuously during normal system voltage variations, system disturbances, and system re-preparation periods.

A disturbance recording device must be installed at the proposed facility with satellite clock synchronization that meets the technical specifications provided by Hydro One. The device will be used to monitor and record the response of the facility to disturbances on the 230 kV system in order to verify the dynamic response of WTGs. The quantities to be recorded, the sampling rate and the

trigger settings will be provided by Hydro One.

The connection applicant should have discussions with the transmitter concerning the tap changer duty cycle of the existing transformers connected in the vicinity of the wind farm.

- End of Section -

4. General Assessment

4.1 Connection Arrangement

The proposed Greenwich Lake shown in Figure 1 will not reduce the level of reliability of the integrated power system and is, therefore, acceptable to the IESO.

4.2 Connection Equipment

RES has provided the following 230 kV equipment specifications for Greenwich Lake Wind Farm:

(1) Switches 89-M23L and 89-M24L

Type – Disconnect

Continuous maximum operating voltage – 250 kV

Continuous current rating – 1200 A

For switches *89-M23L* and *89-M24L*, the Market Rules and Transmission System Code requirements are met.

(2) Breakers 52-H1 and 52-H2

Type – SF6

Continuous maximum operating voltage – 250 kV

Rated interrupting time – 3 cycles (50 ms)

Continuous current rating – 1200 A

Short circuit symmetrical duty – 63 kA

For breakers *52-H1* and *52-H2*, the Market Rules and Transmission System Code requirements are met.

– End of Section –

5. Load Flow Assessment

5.1 Models and Data

- Wind generator, generator step-transformer and collector circuits

The data for the GE generator were provided by the manufacturer. The each step-up transformer is 2.3 MVA. The following step-up transformer equivalent impedances and feeder equivalent impedances are based on the number of turbines connected to the feeder. Note that all figures above are based on 100MVA & 34.5 kV.

| Feeder | Number of WTG | Equivalent Fx | Equivalent Tx |
|--------|---------------|-----------------|-----------------|
| 1 | 17 | 0.036 + j 0.146 | 0.026 + j 0.192 |
| 2 | 16 | 0.038 + j 0.147 | 0.027 + j 0.203 |
| 3 | 17 | 0.013 + j 0.055 | 0.026 + j 0.192 |
| 4 | 16 | 0.085 + j 0.327 | 0.027 + j 0.203 |

The calculations assume that the WTG step up transformer impedance is 5.75% on 1.75 MVA & X/R ratio of 7.5.

- Collector to HT step-up transformer

| Voltage | Maximum Rating | Impedance in pu | Taps |
|-------------|----------------|----------------------------|--------------|
| 34.5/230 kV | 40/50/60 MVA | 0.007+0.07j on 40 MVA base | 228 – 252 kV |

- New 230 kV line (pu values are on 100 MVA base)

| R | X | B | Cont. Rating | LTR | Length |
|------------|-----------|-------------|--------------|-------|--------|
| 0.891 Ω | 5.555 Ω | 35.97 μmhos | 850 A | 950 A | 11 km |
| 0.00168 pu | 0.0105 pu | 0.019 pu | | | |

0.001684 0.010501

- Circuit breakers and switches

| <i>Breakers and switches</i> | LV | HV |
|--------------------------------------|--------|--------|
| Rated line-to-line voltage | 35 kV | 230 kV |
| Interrupting time | - | 50 ms |
| Rated continuous current | 1200 A | 1200 A |
| Rated short circuit breaking current | 20 kA | 63 kA |

- Ratings of existing Hydro One equipment

| | Line section name | Continuous | LTR75 |
|----|----------------------------|------------|--------|
| L1 | M23L (Marathon × Lakehead) | 966 A | 1124 A |
| L2 | M24L (Marathon × Lakehead) | 966 A | 1124 A |

The ratings are based on 35°C temperature at 15 km/s wind speed. For LTR, pre-flow of 75 % of the continuous rating is assumed. The proponent must verify above ratings with Hydro One.

5.2 Current Conditions

The graphs below display the MW flow out M23L, Lakehead TS and MW flow out M23L at Marathon TS. These are hourly average samples from Jan 1 to Dec 31, 2007 obtained from IESO real-time data.

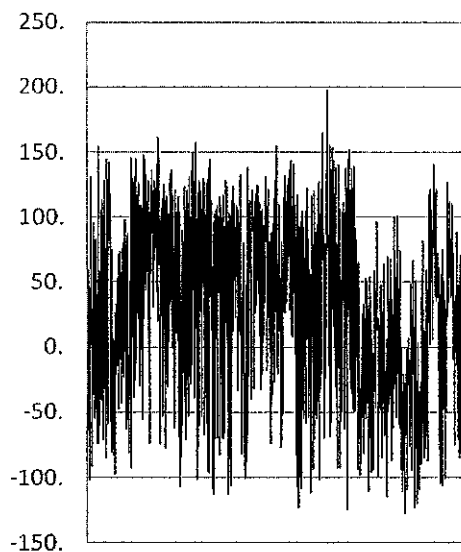

Figure 3: MW flow on M23L at Lakehead TS

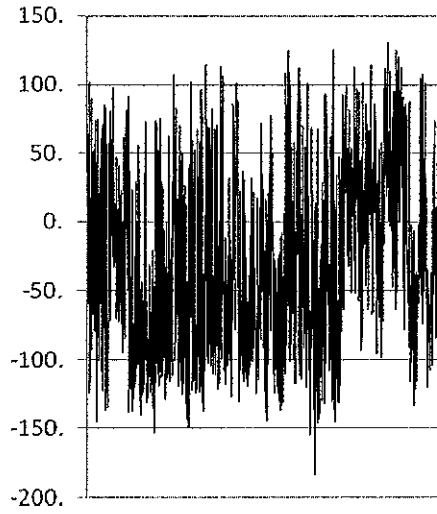

Figure 4: MW flow on M23L at Marathon TS

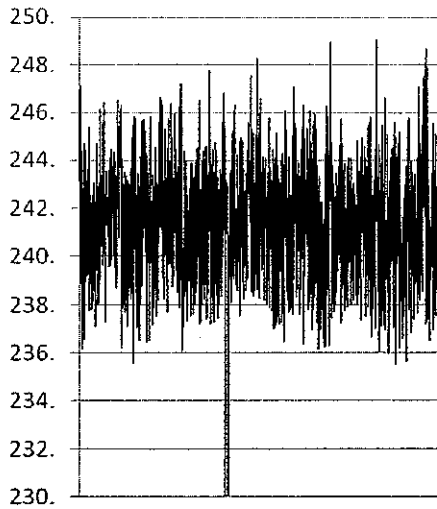

Figure 5: Voltage at Lakehead TS

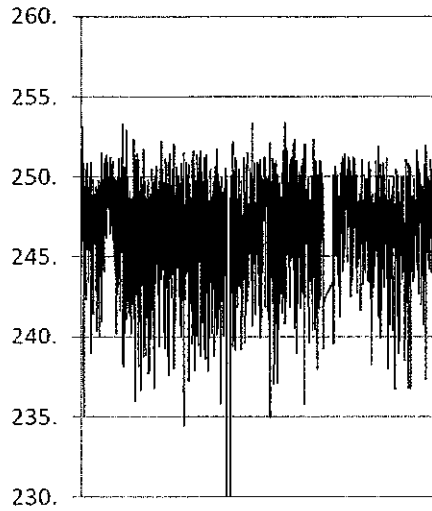

Figure 6: Voltage at Marathon TS

The followings can be observed.

| Lakehead TS | | Marathon TS | |
|--------------------|-----------|--------------------|-----------|
| Average voltage | 241.5 kV | Average voltage | 245.9 kV |
| M23L MW load (max) | 198.3 MW | M23L MW load (max) | 130.5 MW |
| M23L MW load (min) | -128.1 MW | M23L MW load (min) | -183.1 MW |

5.3 Voltage Control

If the generator is connected to the IESO-controlled grid, the IESO requires that the generator assists maintaining voltage in the HT system. It is expected that the wind turbine generators control at minimum, the voltage at the collector bus to a values specified by the IESO. This would need that wind turbines to possess ability to supply sufficient dynamic reactive power to the HT system during voltage declines which in turn may require proponent minimizes the reactive losses occurring in the connection between the generator and the HT system. If these losses are excessive, a supply of additional reactive compensation is required. The following section examined this requirement.

5.3.1 Dynamic Reactive Power Capability

The GE 1.5 MW wind turbine generator is capable of operating continuously at a terminal voltage ranging from 0.9 pu to 1.1 pu of its rated voltage. The generator can operate within a power factor range from 0.9 lagging to 0.9 leading. Thus, the dynamic reactive power capability of the GE 1.5 MW WTG meets the requirements for a similarly rated synchronous generator.

5.3.2 Static Reactive Compensation

Greenwich Lake Wind Farm must have the same capability to supply reactive power continuously as required of a synchronous generator with the same apparent power, as measured at the point of connection to the IESO-controlled grid. With this assumption, Greenwich Lake Wind Farm must have a minimum capability of supplying approximately **+35 MVar** (capacitive) to **-33 MVar** (inductive) at the connection point for at least one constant 230 kV system voltage at all active power outputs.

Load flow studies were performed to justify a need for static reactive compensation. Besides the conditions described in the section '*Model and Data*', additional simulation conditions for these load flow studies include that:

- The 230-kV voltages at Lakehead and Marathon are about 241.1 and 243.8 kV, respectively;
- The terminal voltages of the WTGs vary between 0.9 pu and 1.1 pu;
- The 230 kV tap of the step-up transformer at the interconnection substation is set to the position of 246 kV;

The inductive capability of the generation facility was assessed with the WTGs operating at full active power output. The voltage at the connection point is about 236 kV. The WTG units are operated to control the terminal voltages to their lowest values. The generation facility can absorb a maximum reactive power of **48.2 MVar** at the connection points (23.4 MVar on M22L and 24.8 MVar on M23L), indicating that Greenwich Lake Wind Farm meet the inductive reactive power requirement.

The capacitive capability of the generation facility was assessed with the WTGs operating at full active power output. The voltage at the connection point is about 248 kV. The generation facility can supply a maximum reactive power of **31.6 MVar** at the connection points (17.5 MVar on M23L and 14.1 MVar on M24L) when the WTG units is operated to control the terminal voltages to their highest values. This indicates that static reactive compensation is required to be installed at collector bus #2 to meet the capacitive reactive power requirement.

A capacitor bank, with equipment capacity of **5 MVar@34.5 kV**, is installed at the 34.5 kV bus #2 of the interconnection substation to increase the reactive power injection at the connection point. With this capacitor bank, the wind farm can supply a maximum reactive power of **+35.9 MVar** at the connection point, which meets the capacitive reactive requirement.

5.3.3 Steady State Loading

A limited number of computer simulations were performed to examine the equipment loading in the vicinity of the wind farm at steady-state. Following table summarizes the extent of loading.

| Circuit | Before | | | After | | | Change (MVA) | Rating (MVA) |
|--------------------------|--------|---------|--------|-------|---------|--------|--------------|--------------|
| | P(MW) | Q(MVAr) | S(MVA) | P(MW) | Q(MVAr) | S(MVA) | | |
| M23L/M24L at Lakehead TS | 171 | 9 | 171 | 143 | 1 | 143 | -28 | 385 |
| M23L/M24L at Marathon TS | 161 | 35 | 165 | 181 | 31 | 183 | +20 | 385 |

(*) The ratings are continuous for 235-kV voltage, based on 35°C ambient temperature at 15 km/hr wind velocity, with 93°C maximum operating temperature or individual sag temperature if lower.

It can be seen that the impact of the integration of Greenwich Lake Wind Farm on M23L/M24L flow is small and the flow along the M23L/M24L is well below the circuit continuous rating. Thus, there is no overloading foreseen under normal steady-state operating conditions.

It should be noted that the current absolute East West Transfer East (EWTE) limit of 325 MW is set to respect post contingency phenomenon. The Part 2 SIA analysis will need to verify whether:

- (i) An operating point of EWTE = 325 MW is still valid and
- (ii) EWTE can be increased with the incorporation of Greenwich Lake Wind Farm

In the event that (i) or (ii) cannot be achieved, mitigating measures such as generation rejection, and wind farm output curtailment may need to be assessed.

6. Conclusions and Requirements

The following conclusions and requirements were made after completion of the Part One SIA for the Greenwich Lake Wind Farm:

- The proposed connection arrangement of the facility is acceptable.
- Under the studied conditions, the connection of the proposed facility does not cause any thermal loading impacts on the local transmission facilities.
- A capacitor bank, with equipment capacity of **5 MVar@34.5 kV**, is installed at the 34.5 kV bus #2 of the interconnection substation to increase the reactive power injection at the connection point.
- The 34.5/230 kV transformers may require be equipped with Under Load Tap Changer (ULTC). SIA Part Two Assessment will confirm the need for an ULTC in this project.
- The proposed facility must meet the general requirements listed in Section 3 of this report.

– End of Document –

Greenwich Lake Wind Farm Study Proposal

Renewable Energy Systems Canada inc. (the "Customer") has requested and Hydro One Networks Inc. ("Hydro One") has agreed to perform the Work (as defined in the Scope of Work attached hereto as Schedule "A"), under the Standard Study Agreement Terms and Conditions v. 2 (February 2008) attached hereto as Schedule "B" and both forming a part hereof (the "Agreement") dated *Tuesday, October 14th 2008*.

Proposed Project

The Customer intends to build a new 99 MW generating facility located in *the Municipality of Dorion, Ontario* (the "Generation Facility") that would be connected to Hydro One's 230 kV circuits M23L and M24L through the Customer's electrical system (the "Proposed Project").

The Customer intends to submit the Proposed Project under the Request for Proposals issued by the Ontario Power Authority on August 22, 2008, for approximately 500 MW of Renewable Energy Supply in Ontario (the "RES III RFP").

Information Requirements

The Customer shall provide Hydro One with the following:

1. site location map(s) with suitable details of the line routing and the proposed connection arrangement to Hydro One's facilities;
2. four sets (or single electronic copy) of single line diagrams of the Generation Facility and the electrical modeling data for lines, generators and transformers;
3. four sets (or single electronic copy) of technical descriptions of the operating philosophy of the electrical equipment, and the protection and control philosophy of the Customer's Facilities that could affect Hydro One's transmission system; and
4. a completed joint System Impact Assessment Application (IESO)/Customer Impact Assessment Application (Hydro One) for Generation Facilities which is available at www.HydroOneNetworks.com.

Completion Date:

Provided that the Proposed Project is selected by the Ontario Power Authority as a successful proponent for the RES III RFP, Hydro One Networks shall complete the Work, by no later than sixty (60) Business Days after the latter of:

- (a) the Customer executing this Agreement;
- (b) the Customer paying Hydro One the amount specified below in (b) under the heading "Costs";
- (c) the Customer providing the information described above under the heading "Information Requirements"; and
- (d) the Customer providing Hydro One with a copy of the IESO System Impact Assessment for the Proposed Project.

Impact of Subsequent Changes to the Information Provided by Customer or to the IESO System Impact Assessment

Should the Customer make any changes to the information provided by the Customer as described above under the heading "Information Requirements" after Hydro One has commenced the Work or the IESO makes any changes to the IESO System Impact Assessment and those changes:

- (i) result in an increase in the cost of Hydro One performing the Work above the payment contemplated below under the heading "Costs", the Customer shall make such further payment as may be required by Hydro One in the time specified by Hydro One; and
- (ii) otherwise affect any other provision of this Agreement, such as the time required for completion of the Work, the parties shall negotiate and agree upon the required amendments to this Agreement and Hydro One shall be under no obligation to resume performance of the Work until such time as the parties agree on such amendments.

Costs:

- (a) Should the Proposed Project be selected by the Ontario Power Authority as a successful proponent in the RES III RFP, the Customer shall pay Hydro One's Actual Cost of performing the Work which amount is estimated to be \$15,000.00 (plus applicable Taxes).
- (b) The Customer agrees to pay Hydro One \$15,000.00 (plus applicable Taxes) by no later than ten (10) days after the selection of the Proposed Project in the RES III RFP towards the Actual Cost of the Work.
- (c) Within 90 days after the completion of the Work, Hydro One shall provide the Customer with a final invoice or credit memorandum which shall indicate whether the amounts already paid by the Customer exceed or are less than the Actual Cost of the Work. Any difference between the Actual Cost (plus applicable Taxes) and the amount already paid by the Customer shall be paid within 30 days after the rendering of the said final invoice or credit memorandum, by Hydro One to the Customer, if the amount already paid by the Customer exceeds the Actual Cost (plus applicable Taxes), or by the Customer to Hydro One, if the amount already paid by the Customer is less than the Actual Cost (plus applicable Taxes).

[Intentionally Left Blank]

GST Registration Information

The GST registration number for Hydro One is 87086-5821 RT0001, and the GST registration number for the Customer is 85946 2475 RT0001.

IN WITNESS WHEREOF, the parties hereto have caused this Agreement to be executed by the signatures of their proper officers, as of the day and year first written above.

HYDRO ONE NETWORKS INC.

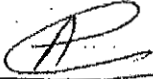

Name: *ADAM GARG*

Title: *Manager, Policy & Approvals*

I have the authority to bind the corporation

Renewable Energy Systems Canada Inc.

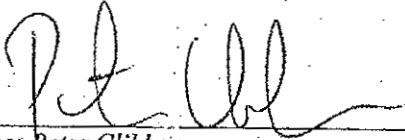

Name: *Peter Clibson*

Title: Director

I have the authority to bind the corporation

SCHEDULE "A": Scope of Work - Customer Impact Assessment

General Description:

Hydro One will prepare a Customer Impact Assessment for the connection of the Proposed Project based on the information provided by the Customer in accordance with the terms of this Agreement.

Customer Impact Assessment Study

The purpose of the study is to assess the impact of the incorporation of the Proposed Project on the transmission customers connected to Hydro One's transmission system in the vicinity of the Proposed Project. The study is intended to supplement the IESO's System Impact Assessment. The study focuses on customer issues and impacts which are outside the scope of the IESO's System Impact Assessment.

The Work will include the following studies to be performed by Hydro One:

- Fault level study analysis
- Voltage performance analysis, and
- Reliability study

Hydro One will provide copies of the Customer Impact Assessment report to the Customer, the Electrical Safety Authority, the affected transmission customers and the IESO.

The affected transmission customers will have thirty (30) Business Days to provide their comments on the Customer Impact Assessment report. Hydro One will issue the Customer Impact Assessment report in its final form fifteen (15) Business Days after receiving comments from the affected transmission customers and the IESO, and after receiving the IESO's final System Impact Assessment for the Proposed Project.

SCHEDULE B – Standard Study Agreement Terms and Conditions

1. Definitions

In the Agreement, unless there is something in the subject matter or context inconsistent therewith, the following words shall have the following meanings:

“**Actual Cost**” means Hydro One’s charge for equipment, labour and materials at Hydro One’s standard rates plus Hydro One’s standard overheads and interest thereon.

“**Applicable Laws**” means any and all applicable laws, including environmental laws, statutes, codes, licensing requirements, treaties, directives, rules, regulations, protocols, policies, by-laws, orders, injunctions, rulings, awards, judgments or decrees or any requirement or decision or agreement with or by any government or government department, commission, board, court or agency.

“**Business Day**” means a day that is not a Saturday, Sunday, statutory holiday in Ontario or any other day on which the principal chartered banks located in the City of Toronto are not open for business during normal banking hours.

“**Code**” means the *Transmission System Code*, the code of standards and requirements issued by the OEB on July 25, 2005 that came into force on August 20, 2005 as published in the Ontario Gazette, as it may be amended, revised or replaced in whole or in part from time to time.

“**Confidential Information**” means:

- (i) the terms of the Agreement and the operations and dealings under the Agreement;
- (ii) all information disclosed by a party to the other party under the Agreement or in negotiating the Agreement which by its nature is confidential to the party disclosing the information, including, but not limited to, Hydro One’s transmission system design and system specifications; and
- (iii) all interpretative reports or other data generated by a party that are based in whole or in part on information that is made Confidential Information by clauses (i) and (ii).

“**Connection Agreement**” means the form of connection agreement appended to the *Code* as Appendix 1, Version A or B, as appropriate to the Customer.

“**Customer’s Facilities**” has the meaning set forth in the *Code*, and includes, but is not limited to any new, modified or replaced Customer’s Facilities.

“**IESO**” means the Independent Electricity System Operator.

“**Good Utility Practice**” has the meaning set forth in the *Code*.

“**OEB**” means the Ontario Energy Board.

“**OEB-Approved Connection Procedures**” means Hydro One’s connection procedures as approved by the OEB from time to time.

“**Person**” shall include individuals, trusts, partnerships, firms and corporation or any other legal entity.

“**Representative**” means (i) a person controlling or controlled by or under common control of a party and each of the respective directors, officers, employees and independent contractors of a party and such party’s Representative, (ii) any consultants, agents or legal, financial or professional advisors of a party or such party’s Representative and (iii) in the case of Customer, any institution providing or considering providing financing for the Proposed Project, including such institution’s directors, officers, employees and independent contractors or its consultants, agents or legal, financial or professional advisors.

“**Taxes**” means all property, municipal, sales, use, value added, goods and services, harmonized and any other non-recoverable taxes and other similar charges (other than Taxes imposed upon income, payroll or capital).

“**Work**” means the work to be conducted in accordance with the Scope of Work attached to the Agreement as Schedule “A”.

2. Representations and Warranties

Each party represents and warrants to the other that:

- (a) it is duly incorporated, formed or registered (as applicable) under the laws of its jurisdiction of incorporation, formation or registration (as applicable);
- (b) it has all the necessary corporate power, authority and capacity to enter into the Agreement and to perform its obligations hereunder;
- (c) the execution, delivery and performance of the Agreement by it has been duly authorized by all necessary corporate and/or governmental and/or other organizational action and does not (or would not with the giving of notice, the lapse of time or the happening of any other event or condition) result in a violation, a breach or a default under or give rise to termination, greater rights or increased costs, amendment or cancellation or the acceleration of any obligation under (i) its charter or by-law instruments; (ii) any material contracts or instruments to which it is bound; or any laws applicable to it;

SCHEDULE B – Standard Study Agreement Terms and Conditions

- (d) any individual executing the Agreement, and any document in connection herewith, on its' behalf has been duly authorized by it to execute The Agreement and has the full power and authority to bind it;
- (e) the Agreement constitutes a legal and binding obligation on it, enforceable against it in accordance with its terms;
- (f) it is registered for purposes of Part IX of the *Excise Tax Act* (Canada); and
- (g) no proceedings have been instituted by or against it with respect to bankruptcy, insolvency, liquidation or dissolution.

3. The Customer and Hydro One shall perform their respective obligations outlined in the Agreement in a manner consistent with Good Utility Practice and in compliance with all Applicable Laws.

4. Except as provided herein, Hydro One makes no representation or warranty, express, implied, statutory or otherwise, including, but not limited to, any representation or warranty as to the merchantability or fitness of the Work or any part thereof for a particular purpose.

5. Customer Covenants

The Customer acknowledges and agrees that:

- (a) Hydro One has informed the Customer that the OEB-Approved Connection Procedures apply to the Proposed Project;
- (b) should the Proposed Project proceed, an agreement must be executed by the Customer and Hydro One to address the terms and conditions (which may include terms with respect to capital contributions required to be made) of Hydro One performing the work required in order to provide for the connection of the Customer's Facilities prior to Hydro One initiating any modifications to Hydro One's facilities or purchasing any equipment;
- (c) the Customer will be responsible for ensuring that the Proposed Project complies with all Applicable Laws;
- (d) if the Proposed Project involves the connection of a Generation Facility (as that term is defined in the *Code*), the Customer shall rectify at its expense, any negative impacts that the connection of the Generation Facility and operation of the Generation Facility following connection may have on Hydro One's transmission system to the satisfaction of Hydro One, acting reasonably;
- (e) if the Proposed Project involves the connection of a Generation Facility (as that term is defined in the *Code*), the Customer is responsible for:
 - i. providing the IESO with the modeling and studies to show the acceptable dynamic behavior of the generators as specified in the IESO Assessment; and
 - ii. any resulting requirements that come from the IESO's review of dynamic studies that were or are not part of the IESO's System Impact Assessment including, but not limited to changes required to be made to the Work as a consequence of such review;
- (f) the Customer shall obtain all applicable approvals required by the IESO for the connection of the Proposed Project;
- (g) all right, title and interest, including copyright ownership, to all information and material of any kind whatsoever (including, but not limited to the work product developed as part of the Work) that may be developed, conceived and/or produced by Hydro One during the performance of the Agreement is the property of Hydro One, and the Customer shall not do any act that may compromise or diminish Hydro One's interest as aforesaid;
- (h) if the Work involves Hydro One preparing a Customer Impact Assessment, the Customer consents, notwithstanding any term to the contrary in the Agreement, to Hydro One releasing the completed Customer Impact Assessment Report to be prepared by Hydro One to the IESO, the Ontario Electrical Safety Authority and customers connected to Hydro One's transmission system in the vicinity of the Proposed Project that may be affected by the Proposed Project;
- (i) if the Work involves Hydro One preparing a Customer Impact Assessment, it may provide a deposit to the IESO for the IESO studies in relation to the Proposed Project. In the event that the IESO refunds part of the deposit to Hydro One, Hydro One will refund such funds to the Customer within 30 days of receipt by Hydro One. In the event that the IESO studies cost more than the deposit, the Customer agrees that it will pay the additional costs of such studies as invoiced to Hydro One by the IESO; and
- (j) Hydro One performs the Work based on the system conditions at the time the Work is performed, should there be any changes to system conditions between the time that Hydro One completes the Work and when the Customer proposes to connect the

SCHEDULE B – Standard Study Agreement Terms and Conditions

Proposed Project, the Work may have to be revised at the Customer's expense at that time.

6. Code Revisions and Amendments

This Agreement is subject to the *Transmission System Code* and the OEB-Approved Connection Procedures. If any provision of this Agreement is inconsistent with the:

- (a) *Transmission System Code*, the said provision shall be deemed to be amended so as to comply with the *Transmission System Code*; or
- (b) OEB-Approved Connection Procedures the said provision shall be deemed to be amended so as to comply with the OEB-Approved Connection Procedures.

7. Liability and Force Majeure

PART III: LIABILITY AND FORCE MAJEURE and Sections I.1.12 and I.1.17 of the Connection Agreement are hereby incorporated in their entirety by reference into, and form an integral part of the Agreement. Unless the context otherwise requires, all references in PART III: LIABILITY AND FORCE MAJEURE TO "the Agreement" shall be deemed to be a reference to the Agreement and all references to the "the Transmitter" shall be deemed to be a reference to Hydro One.

For the purposes of this Section 8, the Parties agree that the reference to:

- (i) the Transmitter in lines 3 and 4 of Section 15.1 of the Connection Agreement means the Transmitter or any party acting on behalf of the Transmitter such as contractors, subcontractors, suppliers, employees and agents; and
- (ii) the Customer in lines 3 and 4 of Section 15.2 of the Connection Agreement means the Customer or any party acting on behalf of the Customer such as contractors, subcontractors, suppliers, employees and agents.

This Section 7 shall survive the termination of the Agreement.

8. Confidential Information

8.1 Disclosures of Confidential Information

Pursuant to the terms and conditions contained herein, a party may disclose Confidential Information to the other party solely for the purpose of the Proposed Project or the Work. Notwithstanding such disclosure the Confidential Information shall remain the sole and exclusive property of the disclosing party and as such shall be maintained in confidence by the receiving party

using the same care and discretion to avoid disclosure as the receiving party uses with its own similar information that it does not wish to disclose. The receiving party may disclose Confidential Information to its Representatives pursuant to Section 4 below but may not use or disclose it to others without the disclosing party's prior written consent. Notwithstanding the generality of the foregoing, all intellectual property rights which may subsist in the Confidential Information shall remain with the disclosing party. The receiving party shall not use the confidential information for any purposes other than the Proposed Project or the Work without the disclosing party's prior written consent.

8.2. Information that is not Confidential

Confidential Information shall not include information which:

- (a) is previously known to or lawfully in the possession of the receiving party prior to the date of disclosure as evidenced by the receiving party's written record;
- (b) is independently known to or discovered by the receiving party, without any reference to the Confidential Information;
- (c) is obtained by the receiving party from an arm's length third party having a bona fide right to disclose same and who was not otherwise under an obligation of confidence or fiduciary duty to the disclosing party or its Representatives;
- (d) is or becomes publicly available through no fault or omission of, or breach of this Schedule "B" by, the receiving party or its Representatives;
- (e) is disclosed by the disclosing party to another entity without obligation of confidentiality;
- (f) is required to be disclosed on a non-confidential basis by operation of law or pursuant to a final judicial or governmental order;
- (g) is disclosed in the circumstances described in Section 4.7.2 of the Code; or
- (h) is contained in the Customer Impact Assessment report prepared by Hydro One and released by Hydro One to customers connected to Hydro One's transmission system in the vicinity of the Proposed Project that may be affected by the Proposed Project, the Ontario Electrical Safety Authority and the IESO.

8.3. Disclosure to Representatives

Confidential Information shall only be disclosed to Representatives who need to know the Confidential Information for the purposes of the Proposed Project or the Work. Except in the case of officers, directors or employees, Confidential Information may only be disclosed to Representatives where the receiving party has an agreement in place with those Representatives sufficient to obligate them to treat the Confidential

SCHEDULE B - Standard Study Agreement Terms and Conditions

Information in accordance with the terms hereof. The receiving party hereby specifically acknowledges that it shall be solely responsible to ensure that its representatives comply with the terms of this Section 8 and that the receiving party shall defend, indemnify and hold harmless the disclosing party from and against all suits, actions, damages, claims and costs arising out of any breach of this Section 8 by the receiving party or any of its Representatives.

8.4 Compelled Disclosure

In the event that a receiving party, or anyone to whom a receiving party transmits Confidential Information pursuant to this Section 8 or otherwise, becomes legally compelled to disclose any Confidential Information, the receiving party will provide the disclosing party with prompt notice so that the disclosing party may seek injunctive relief or other appropriate remedies. In the event that both parties are unable to prevent the further transmission of the Confidential Information, the receiving party will, or will use reasonable efforts to cause such person to whom the receiving party transmitted the Confidential Information to furnish only that portion of the Confidential Information, which the receiving party is advised by written opinion of counsel is legally required to be furnished by the receiving party, to such person and exercise reasonable efforts to obtain assurances that confidential treatment will be afforded to that portion of the Confidential Information so furnished.

8.5 Records with respect to Confidential Information

The receiving party shall keep all written or electronic confidential information furnished to or created by it. All such Confidential Information, including that portion of the Confidential Information which consists of analyses, compilations, studies or other documents prepared by the receiving party or by its Representatives, is the disclosing party's property and will be returned immediately to the disclosing party or destroyed upon its request and the receiving party agrees not to retain any copies, extracts or other reproductions in whole or in part. If a receiving party does not receive a request to return Confidential Information to the disclosing party within six months of the last communication between the parties concerning the Proposed Project or the Work then the receiving party shall destroy any Confidential Information it holds.

Notwithstanding the foregoing and provided that the Proposed Project is connected to Hydro One's transmission system, Hydro One shall have the right to retain such electrical information concerning the Proposed Project that it has received from the Customer or its Representatives for the purpose of Hydro One

making the required calculations and decisions related to the design, operation, and maintenance of Hydro One's facilities and those for any other person that may connect or is considering connecting to Hydro One's transmission system that could be impacted by or could impact the Proposed Project.

8.6 Remedies

The receiving party agrees that the disclosing party would be irreparably injured by a breach of this Section 8 and that the disclosing party shall be entitled to equitable relief, including a restraining order, injunctive relief, specific performance and/or other relief as may be granted by a court to prevent breaches of this Section 8 and to enforce specifically the terms and provision hereof in any action instituted in any court having subject matter jurisdiction, in addition to any other remedy to which the disclosing party may be entitled at law or in equity in the event of any breach of the provisions hereof. Such remedies shall not be deemed to be the exclusive remedies for a breach of this Section 8 but shall be in addition to all other remedies available at law or equity.

8.7 Term

The obligations in this Section 8 shall be effective as of the date of this Agreement and shall remain in force and effect in perpetuity unless modified by further written agreement of the parties.

9. General

(a) Subject to Section 6, no amendment, modification or supplement to the Agreement or any waiver shall be valid or binding unless set out in writing and executed by the parties with the same degree of formality as the execution of the Agreement.

(b) The failure of either party hereto to enforce at any time any of the provisions of the Agreement or to exercise any right or option which is herein provided shall in no way be construed to be a waiver of such provision or any other provision nor in any way affect the validity of the Agreement or any part hereof or the right of either party to enforce thereafter each and every provision and to exercise any right or option. The waiver of any breach of the Agreement shall not be held to be a waiver of any other or subsequent breach. Nothing shall be construed or have the effect of a waiver except an instrument in writing signed by a duly authorized officer of the party against whom such waiver is sought to be enforced which expressly waives a right or rights or an option or options under the Agreement.

(c) The Agreement may not be assigned without the written consent of the other party, which consent will not be unreasonably withheld.

SCHEDULE B – Standard Study Agreement Terms and Conditions

(d) The Agreement may be executed in counterparts, including facsimile counterparts, each of which shall be deemed an original, but all of which shall together constitute one and the same agreement.

(e) The Agreement shall be construed and enforced in accordance with, and the rights of the parties shall be governed by, the laws of the Province of Ontario and the laws of Canada applicable therein.

(f) Invoiced amounts are due 30 days after invoice issuance. All overdue amounts including, but not limited to amounts that are not invoiced but required under the terms of this Agreement to be paid in a specified time period, shall bear interest at 1.5% per month compounded monthly (19.56 percent per year) for the time they remain unpaid.

(g) The obligation to pay any amount due and payable hereunder shall survive the termination of the Agreement.

(h) The Agreement will supersede the terms of any purchase orders issued by the Customer to Hydro One in respect of the Proposed Project irrespective of whether same have been issued by Customer and/or accepted by Hydro One on or after the execution of this Agreement by the Customer.

CONFIDENTIAL DOCUMENT

TAB F-3-2